

The Columbia Locking Mailbox

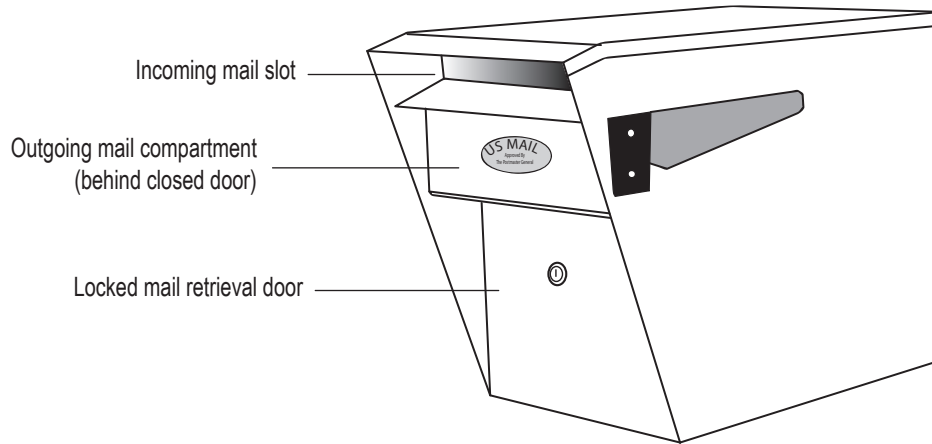

THE COLUMBIA MAILBOX PART OF THE NORTHWEST SERIES

This popular locking mailbox works well for both residential and commercial applications. Oversize incoming mail slot will accept a box of checks, catalogs, Priority Mail envelopes, and more. Features include: A convenient non-locking outgoing mail shelf, roomy interior, and an extra-strength lock.

USPS APPROVED

DOES NOT REQUIRE U.S.P.S. MASTER LOCK

- Overall size: 15" H x 10 - 5/8" W (with flag) x 21" D
- Incoming mail slot size: 2 - 1/8" H x 10 - 1/8" W
- Material: Galvanized steel: Top & sides = 18 gauge, Bottom pan = 16 gauge, Door = 12 gauge
- Finish: Durable powder coat
- Colors: Black, Stone Gray, White, Pearl Taupe, Mallard Green, and Juniper Green

Posts are sold separately. Standard, in-ground, surface-mount and decorative posts available. Matching newspaper boxes are also available for an integrated and uniform installation with the Columbia mailbox.

CUT-AWAY VIEW

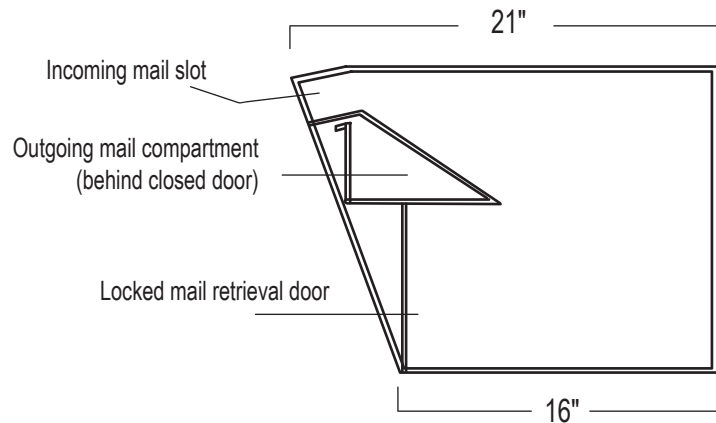

Manufactured By:



19350 SW 118th
Tualatin, OR 97062
800.630.3344 fx 503.682.1520
www.mbx.com
CCBF 134768